

ACECO

Valve, Inc.



PV3



PV4

Model PV 3 & PV 4 Pig Valves

Features

- Compact body style for bolting between line flanges. Space saving. See dimension chart for end to end lengths.
- During pig loading and retrieving, by-pass design permits 72 to plus 100 percent of product flow, depending on pipe schedule.
- No tools required for removing or replacing bonnet plug.
- Vent/bleeder valve permits the relieving of pressure from the bonnet pig chamber for safety before removing bonnet plug.
- Equalizer valve opens to pressurize bonnet pig chamber to create low torque operation.
- Pig launching and removal is performed easily and safely.
- Back-seated stem prevents blowout.
- Stem lubrication fitting standard.
- 90° stem rotation and locking plates standard.
- Valves are field convertible from launching type to receiving type or vice-versa.
- Pig receiving ball contains pig stop plate rigidly positioned to stop pig.
- Lower seat is spring energized to force ball upward to create initial seal against upper seat to isolate bonnet pig chamber. Line pressure then increases seat sealing.
- In-line field repairable
- Materials available for all requirements.
- Materials per Nace specification MR-01-75 standard
- Manufactured in compliance to ISO 9000 standards for quality control.
- Bonnet plug color coded for proper field installation "green" for launching valves "red" for receiving valves.
- Correct size grade B-7 installation cap screws furnished with valves.

Operating Procedure

Launching

The launching valve is installed in the flow line with the bonnet plug facing vertically upward within 0-45 degrees.

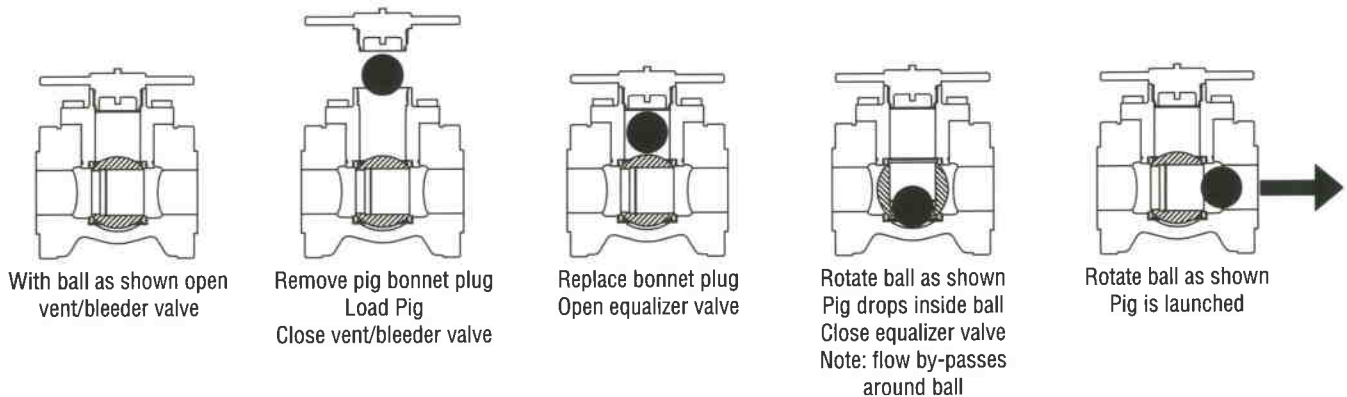

Receiving

The receiving valve is installed in the flow line with the bonnet plug facing vertically downward within 0-45 degrees.

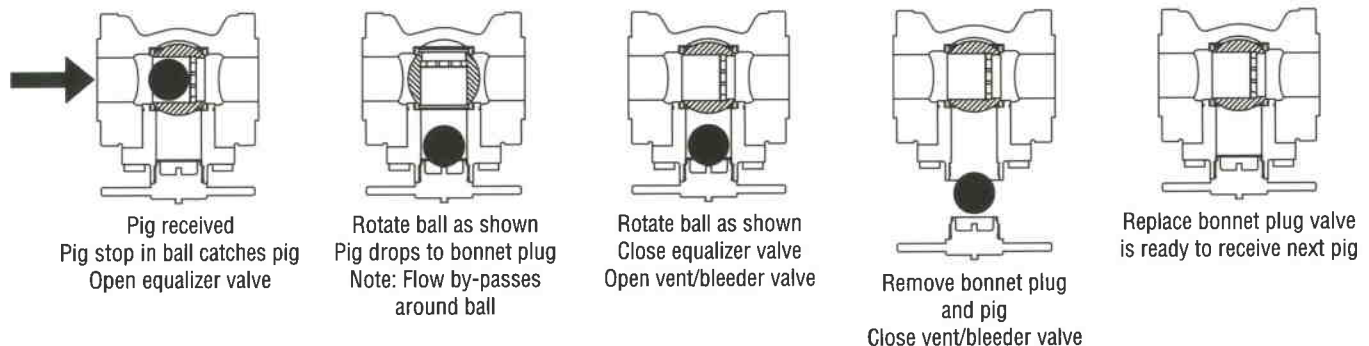

Parts List for Model PV3

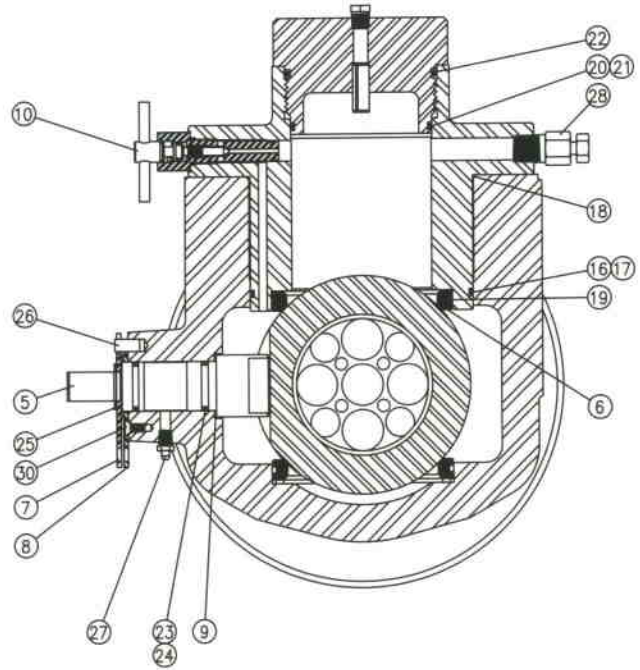
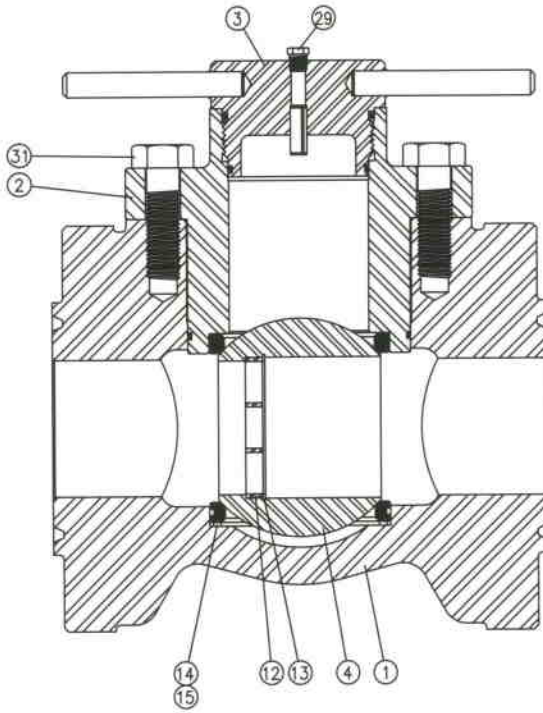

Item No.	Part Name
1	Body
2	Bonnet
3	Pig Entry Plug
4	Ball
5	Stem
6	Seat
7	Stop Plate
8	Lock Plate
9	Stem Thrust Bearing / Spacer
10	Equalizer Valve Assembly
11	Handle
* 12	Pig Stop
* 13	Pig Stop Retainer Ring
14	Wave Spring
15	Shim
16	Bonnet / Body Seal
17	Bonnet / Body Back-up Ring

* FOR RECEIVING PIG VALVES ONLY

Item No.	Part Name
18	Bonnet / Body Weather Seal
19	Seat Seal
20	Pig Entry Plug Seal
21	Pig Entry Plug Back-up Ring
22	Pig Entry Plug Weather Seal
23	Stem Seal
24	Stem Back-up Ring
25	Retainer Ring
26	Stop Pin
27	Stem Lubrication Fitting
28	Body Vent / Bleeder Fitting
29	Pipe Plug
30	Lock Plate Retaining Screw
31	Cap Screw
32	Name Plate
33	Drive Screw

NOT SHOWN 11, 32, 33

Dimensions for Model PV3

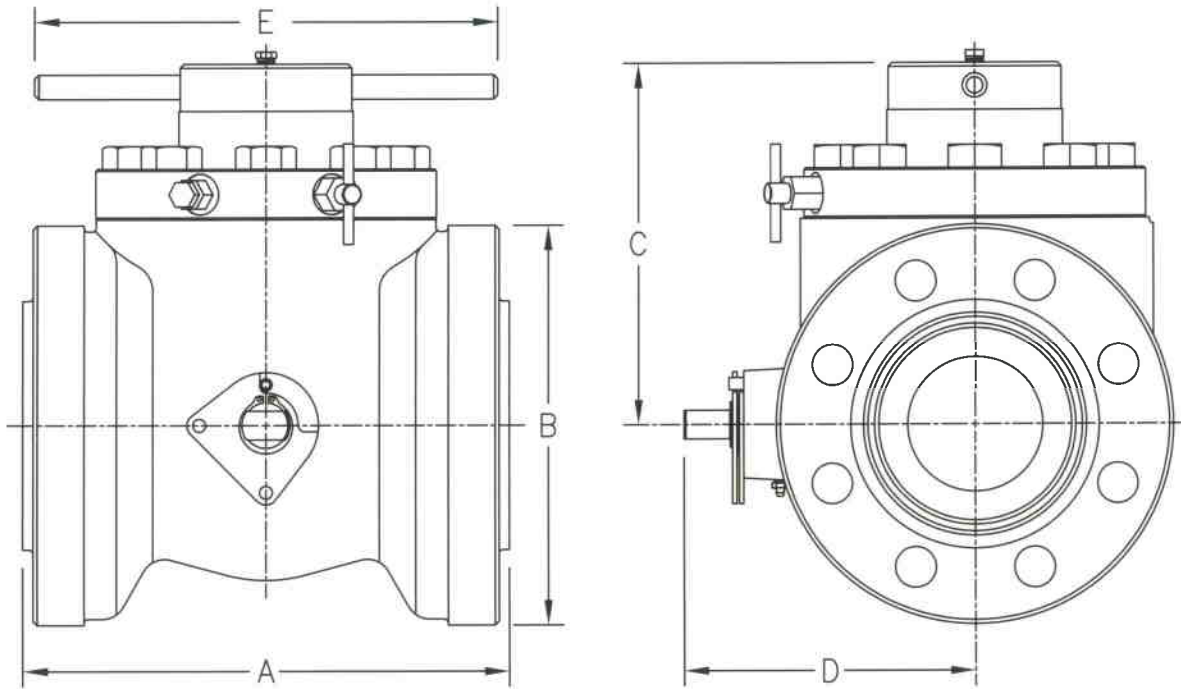

Valve Size		A	B	C	D	E	Handle Length
3"	600 RF	11.375	8.25	8.63	7.34	10.30	16
	600 RTJ OR 2000 API	11.375	8.25	8.63	7.34	10.30	
	900 RF	12.500	10.50	9.83	7.97	10.30	
	900 RTJ OR 3000 API	12.500	10.50	9.83	7.97	10.30	
	1500 RF	12.500	10.50	9.83	7.97	10.30	
	1500 RTJ OR 5000 API	12.500	10.50	9.83	7.97	10.30	
4"	600 RF	13.625	10.75	10.25	8.34	12.30	16
	600 RTJ OR 2000 API	13.625	10.75	10.25	8.34	12.30	
	900 RF	15.000	12.25	11.07	8.97	12.30	
	900 RTJ OR 3000 API	15.000	12.25	11.07	8.97	12.30	
	1500 RF	15.000	12.25	11.07	8.97	12.30	
	1500 RTJ OR 5000 API	15.000	12.25	11.07	8.97	12.30	
6"	600 RF	16.875	14.00	12.72	10.28	14.38	16
	600 RTJ OR 2000 API	16.875	14.00	12.72	10.28	14.38	
	900 RF	18.250	15.00	13.41	11.22	14.38	
	900 RTJ OR 3000 API	18.250	15.00	13.41	11.22	14.38	
	1500 RF	18.250	15.50	13.41	11.22	14.38	
	1500 RTJ OR 5000 API	18.250	15.50	13.41	11.22	14.38	
8"	600 RF	20.750	16.50	15.62	13.05	16.50	16
	600 RTJ OR 2000 API	20.750	16.50	15.62	13.05	16.50	
	900 RF	22.750	18.50	16.88	14.30	16.50	
	900 RTJ OR 3000 API	22.750	18.50	16.88	14.30	16.50	
	1500 RF	24.000	19.00	16.88	14.30	16.50	
	1500 RTJ OR 5000 API	24.000	19.00	16.88	14.30	16.50	
10"	150 RF POLY PIPE	22.000	17.75	22.94	13.05	17.50	16
	300 RF POLY PIPE	22.000	17.75	22.94	13.05	17.50	
12"	150 RF POLY PIPE	22.750	18.50	16.88	14.85	19.50	16
	300 RF POLY PIPE	22.750	18.50	16.88	14.85	19.50	

DESIGN AND SPECIFICATIONS SUBJECT TO CHANGE WITHOUT NOTICE
 CONSULT FACTORY FOR OTHER SIZES AND PRESSURE CLASSES

Percent of by-pass product flow with ball closed to load or retrieve pig

Pipe Schedule		Pipe I.D.	Pipe Flow Area Sq. In.	Valve By-Pass Area Sq. In.	Flow By-Pass Area %
2"	40	2.067	3.355	4.352	129.7
	80 XS	1.939	2.952	4.352	147.4
	160	1.689	2.240	4.352	194.2
	XXS	1.503	1.774	4.352	245.3
3"	40	3.068	7.393	6.556	88.6
	80 XS	2.900	6.605	6.556	99.2
	160	2.642	5.408	6.556	121.2
	XXS	2.300	4.154	6.556	157.8
4"	40	4.026	12.730	9.914	77.8
	80 XS	3.826	11.497	9.914	86.2
	120	3.624	10.315	9.914	96.1
	160	3.438	9.283	9.914	106.7
	XXS	3.152	7.803	9.914	127.0
6"	40	6.065	28.890	21.042	72.8
	80 XS	5.761	26.066	21.042	80.7
	120	5.501	23.766	21.042	88.5
	160	5.189	21.147	21.042	99.5
	XXS	4.897	18.834	21.042	111.7
8"	40	7.981	50.027	37.437	74.8
	60	7.813	47.943	37.437	78.0
	80 XS	7.625	45.663	37.437	81.9
	100	7.439	43.463	37.437	86.1
	120	7.189	40.590	37.437	92.2
	140	7.001	38.495	37.437	97.2
	XXS	6.875	37.122	37.437	100.8
	160	6.813	36.455	37.437	102.6

Features

- Trunnion type ball for reduced operating torque.
- No tools required for removing or replacing body plug.
- Optional body cavity pressure indicator for all valves for safety. Special order.
- Body cavity venting for safety.
- More compact and lighter weight than competitive pigging valves results in lower costs.
- Double block and bleed design.
- May be used as a positive shut-off fowline valve.
- For bullet and spherical style pigs.
- Backseated stem provides blowout prevention.
- Stem lubrication capability standard.
- Self lubricating acetal copolymer material ball seats.
- 90° stem rotation and locking plates standard.
- Iso 9000 standards for quality control.
- Materials available for all media requirements.
- Plug color coded for proper field installation. "Green" for launching valves. "Red" for receiving valves.

Operating Procedure

Launching

The launching valve is installed in the flow line with the body plug facing vertically upward within 0-30 degrees.

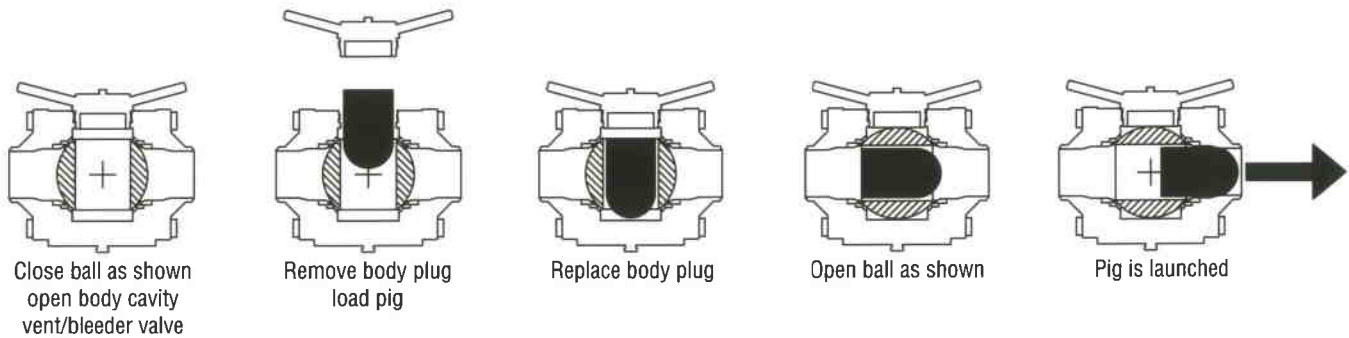

Receiving

The receiving valve is installed in the flow line with the body plug facing vertically downward within 0-30 degrees.

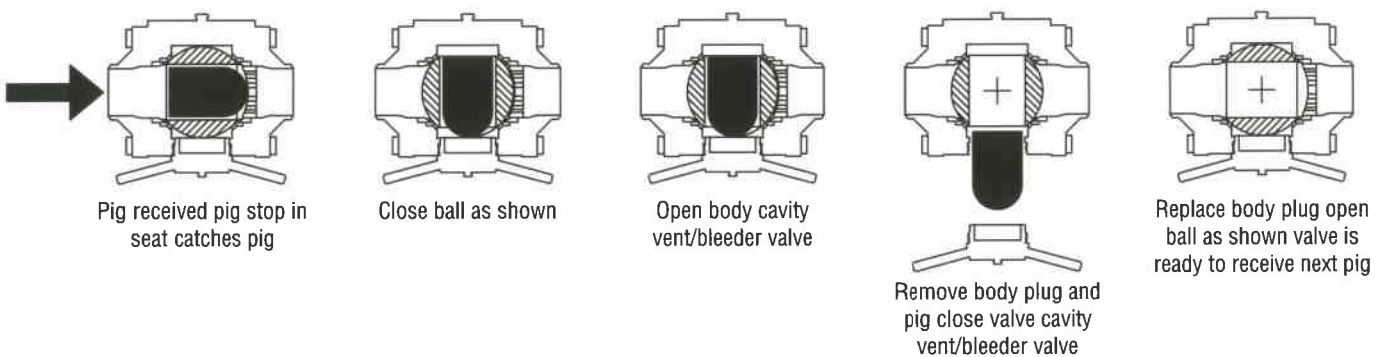

Parts List For Model PV4 Weldneck Pig Valve

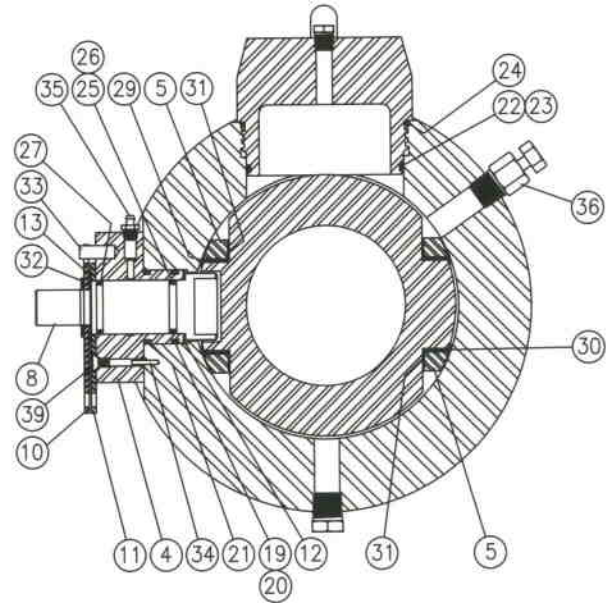
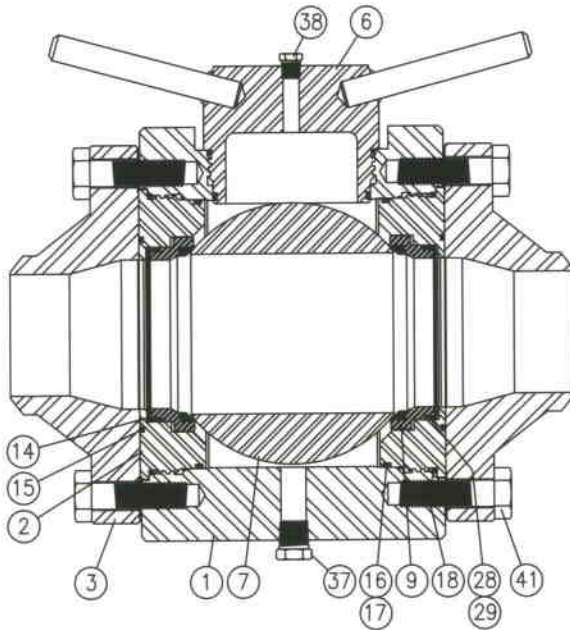

Item No.	Part Name
1	Body
2	Seat Retainer
3	Weldneck Flange
4	Bonnet
5	Trunnion Bearing Retainer
6	Pig Entry Plug
7	Ball
8	Stem
9	Seat Assembly
10	Stop Plate
11	Lock Plate
12	Stem Thrust Bearing
13	Spacer
14	Wave Spring
15	Face Seal
16	Seat Retainer / Body Seal
17	Seat Retainer / Body Back-up Ring
18	Seat Retainer / Body Seal
19	Bonnet Seal
20	Bonnet Back-up Ring
21	Bonnet Seal
22	Pig Entry Plug Seal
23	Pig Entry Plug Back-up Ring

* FOR RECEIVING VALVES ONLY

Item No.	Part Name
24	Pig Entry Plug Seal
25	Stem Seal
26	Stem Back-up Ring
27	Stem Weather Seal
28	Seat Assembly Seal
29	Seat Assembly Back-up Ring
30	Trunnion Bearing
31	Trunnion Shim
32	Retainer Ring
33	Stop Pin
34	Bonnet Positioning Pin
35	Stem Lubrication Fitting
36	Body Vent / Bleeder Fitting
37	Pipe Plug
38	Pipe Plug
39	Lock Plate Retaining Screw
40	Bonnet Cap Screw
41	Weldneck Flange Cap Screw
42	Name Plate
43	Drive Screw
* 44	Pig Stop
* 45	Pig Stop Retainer

40, 42, 43, 44, 45 NOT SHOWN

ITEM NO'S 10, 11, 13, 32, 33, 39 OMITTED ON
 6" - 600, 900, 1500
 8" - 150, 300, 600, 900, 1500

Dimensions for Model PV4 Pig Valve with Weldneck Flanges

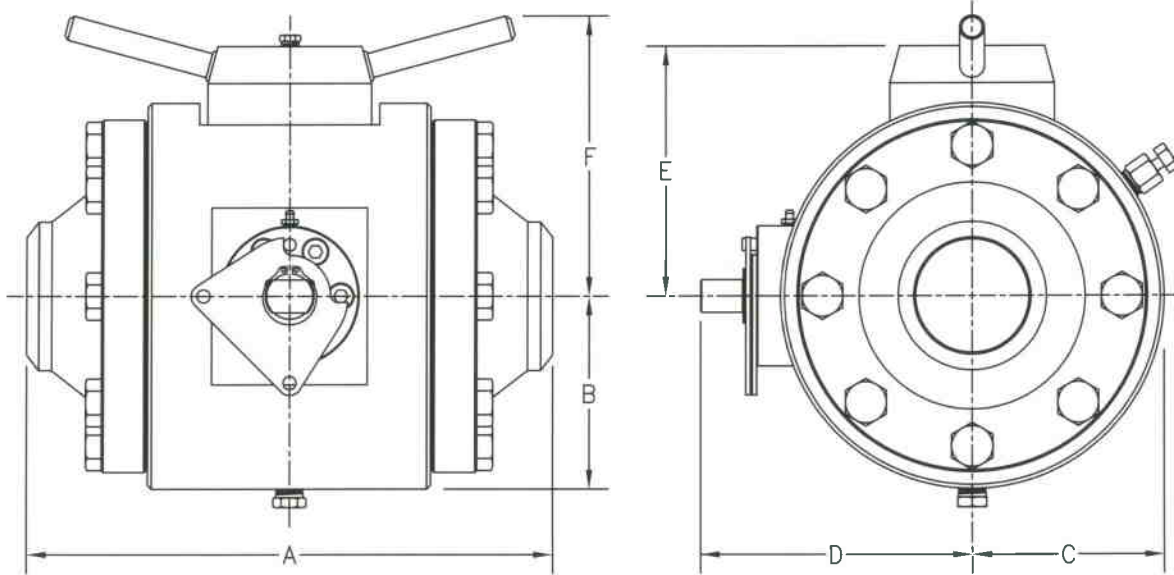

Note: Customer to specify pipe schedule on purchase order

Valve Size		A	B	C	D	E	F	Handle Length	Bullet Pig Max. Length
2"	ANSI 150	11.00	4.000	4.000	6.490	4.925	5.815	18	4.00
	ANSI 300	11.000	4.000	4.000	6.490	4.925	5.815		
	ANSI 600	11.000	4.000	4.000	6.490	4.925	5.815		
	ANSI 900	13.250	4.000	4.000	6.490	4.925	5.815		
	ANSI 1500	13.250	4.000	4.000	6.490	4.925	5.815		
3"	ANSI 150	13.000	5.000	5.000	7.570	6.675	7.425	22	5.00
	ANSI 300	13.500	5.000	5.000	7.570	6.675	7.425		
	ANSI 600	13.500	5.000	5.000	7.570	6.675	7.425		
	ANSI 900	14.750	5.000	5.000	7.570	6.675	7.425		
	ANSI 1500	15.250	5.000	5.000	7.570	6.675	7.425		
4"	ANSI 150	16.000	5.850	5.850	8.275	7.570	8.490	30	6.50
	ANSI 300	16.000	5.850	5.850	8.275	7.570	8.490		
	ANSI 600	16.000	5.850	5.850	8.275	7.570	8.490		
	ANSI 900	16.500	5.850	5.850	8.275	7.570	8.490		
	ANSI 1500	17.000	5.850	5.850	8.275	7.570	8.490		
6"	ANSI 150	19.250	8.210	8.210	10.795	10.020	10.940	38	9.25
	ANSI 300	19.250	8.210	8.210	10.795	10.020	10.940		
	ANSI 600	20.000	8.210	8.210	12.010	10.020	10.940		
	ANSI 900	20.500	8.210	8.210	12.010	10.020	10.940		
	ANSI 1500	22.000	8.210	8.210	12.010	10.020	10.940		
8"	ANSI 150	22.500	10.000	10.000	13.985	12.050	13.220	GEAR OPERATOR REQUIRED	12.00
	ANSI 300	22.500	10.000	10.000	13.985	12.050	13.220		
	ANSI 600	24.750	10.000	10.000	14.565	12.675	13.845		
	ANSI 900	27.000	10.400	10.400	14.565	12.675	13.845		
	ANSI 1500	27.000	10.400	10.400	14.565	12.675	13.845		

DESIGN AND SPECIFICATIONS SUBJECT TO CHANGE WITHOUT NOTICE